

PANEL ROOF SYSTEMS

Insureds of FM Global should contact their local FM Global office before beginning any roofing work.

Table of Contents

	Page
1.0 SCOPE	3
1.1 Hazards	3
1.2 Changes	3
2.0 LOSS PREVENTION RECOMMENDATIONS	4
2.1 Introduction	4
2.2 Construction and Location	4
2.2.1 General	4
2.2.2 Wind Resistance	4
2.2.3 Gravity Loads	8
2.2.4 Re-Cover of Existing Metal Roof Systems	8
2.2.5 Metal Roof Systems Used to Re-Cover Other Existing Metal Roofs	9
2.3 Operation and Maintenance	11
3.0 SUPPORT FOR RECOMMENDATIONS	12
3.1 Additional Information	12
3.1.1 Structural Design	12
3.1.2 Oriented Strand Board (OSB)/Composite Systems	12
3.1.3 Re-Cover of Metal Roof Systems	13
3.1.4 Roof Areas Needing Increased Fastening	13
3.1.5 Wind Resistance of Standing Seam Roofs	15
3.1.6 Providing Enhancements for Existing SSRs and Leakage Concerns	15
3.1.7 Sub-Purlins Used for the Securement of FM Approved Panel Roofs Over Existing Roofs ..	15
3.2 Roof Walkways	15
4.0 REFERENCES	16
4.1 FM Global	16
4.2 Others	16
APPENDIX A GLOSSARY OF TERMS	16
APPENDIX B DOCUMENT REVISION HISTORY	17
APPENDIX C SUPPLEMENTARY INFORMATION	18
C.1 Metal Panel Types	18
C.1.1 Standing Seam and Lap Seam Roofs	18
C.1.2 Insulated Roof Deck Panels	18
C.2 OSB/Composite Systems	19
C.3 Re-Cover of Metal Roof Systems	19
C.4 Metal Roof Systems Used for Re-Cover	19

List of Figures

Fig. 1. One piece clip (left) vs. two-piece clip (right)	6
Fig. 2. Note the top part of the internal clip has two separated pieces (left) and requires two ESC (right) .	6
Fig. 3. Skylight for usse in SSR panels	7
Fig. 4. Re-roof assembly with noncombustible or Class 1 insulation added above the existing roof and no concealed spaces	10
Fig. 5. Standing seam roof in re-cover construction resulting in a concealed space	11



Fig. 6. FM Approved Standing seam roof applied to OSB/composite insulation
Redraw to make steel deck deeper and label top flange of deck 12

Fig. 7. Typical re-cover of existing standing seam roof using a mechanically fastened single-ply roof cover . 14

List of Tables

Table 1. Recommended Rating of Field, Perimeter, and Corner Areas for Enclosed Buildings
(Zones 1, 2, and 3) 5

Table 2. Use of ESC for Prescriptive Enhancement of FM Approved SSR in Tropical Cyclone-Prone
Regions 5

1.0 SCOPE

A. This data sheet provides loss prevention recommendations for the following:

1. Wind resistance, installation, and maintenance of standing seam metal roofs (SSR), lap seam (metal and plastic) roofs (LSR), and insulated metal panel (IMP) and composite panel roof systems
2. Resistance to snow, ice, and rain loads for secondary structural members (e.g., joists, purlins) supporting standing seam roofs (see Data Sheet 1-54, *Roof Loads for New Construction*, for additional information on gravity loads, including those on primary building frames)
3. Fire and hail concerns for all panel-type roofs
4. Wind-related concerns for skylights used in panel roof systems

Information is included on new construction, re-covers over existing metal roof systems, and use of metal roof systems in re-covering existing low-sloped roofs.

Information and recommendations are applicable to all types of panel roof systems unless noted otherwise. For details and ratings, refer to RoofNav for roof assemblies, and the *Approval Guide* for skylights.

B. This data sheet **does** not provide loss prevention recommendations for the following:

1. Rain, ice, and snow loads; see DS 1-54. Also see DS 1-54 for possible concerns related to snow drifting caused by the presence of roof-mounted PV modules.
2. Securement of roof-mounted solar photovoltaic (PV) modules; see DS 1-15. For wind design of other roof-mounted equipment, see DS 1-28, *Wind Design*.
3. Wind loads on panel roof systems; see DS 1-28, *Wind Design*.
4. Fire-related concerns for skylights; see DS 1-57, *Plastics in Construction*.
5. Any concerns related to weak construction; see DS 1-55, *Weak Construction*.

1.1 Hazards

Wind pressure can cause failure of inadequately designed or installed panel roof systems and skylights, resulting in water damage to the building interior and its contents.

Inadequate bracing (i.e., bracing that does not comply with this data sheet) of purlins that support standing seam metal roofs can result in collapse from gravity loads such as snow, ice, and rain.

Hail can cause damage to any panel roof system or skylights.

The use of unacceptable insulations, insulation facers, or assemblies can result in fire spread on the undersides or tops of roofs.

The installation of new panel roofs over existing insulated roof assemblies can result in the potential for concealed space fires.

1.2 Changes

July 2016. This data sheet has been completely revised. Major changes include the following:

- A. Changed the title of the document from Metal Roof Systems to Panel Roof Systems to reflect that wind guidance is also to be applied to through-fastened plastic and composite panel roof systems.
- B. Added information regarding the use of external seam clamps (ESC) to increase the wind resistance of standing seam roofs (SSR). This information applies to the enhancement of new installations and retrofitting of existing installations.

2.0 LOSS PREVENTION RECOMMENDATIONS

2.1 Introduction

The recommendations in this data sheet are not intended to supersede the requirements of any FM Approval. They should be used to supplement the RoofNav and *Approval Guide* listings. For all applications, follow Sections 2.2.1, 2.2.2, and 2.2.3. For re-covers, follow the specific applicable recommendations in Section 2.2.4 or 2.2.5.

2.2 Construction and Location

2.2.1 General

2.2.1.1 For protection of new or re-cover construction of metal roof systems installed adjacent to maximum foreseeable loss (MFL) fire walls, refer to Data Sheet 1-22.

2.2.1.2 Do not use perforated liner panels in panel roof systems where the occupancy uses or produces a considerable amount of dust, oil, or oil mist. There have been cases in which the dust or oil has collected inside the panels, greatly increasing the fire spread potential.

2.2.1.3 Provide thorough supervision via the building owner's qualified representative during all roof construction to ensure quality of workmanship and adherence to FM Global property loss prevention data sheets and project specifications.

2.2.1.4 Design roof drains to prevent the accumulation of hail from obstructing water flow to the drains. Additional guidance on roof drainage can be found in DS 1-54.

2.2.1.5 Provide a water-tight seal between the gutters and the underside of the roof to ensure rainwater will not enter the building nor breach the building's water-tight envelope. Loss experience shows that it is common for rainwater to enter the building in these areas, particularly if roof gutters or drainage troughs are adjacent to the roof eaves.

2.2.1.6 Use materials that are compatible to prevent galvanic corrosion, as verified by the roof panel manufacturer (e.g., for panels, panel clips, carbon steel purlins and screws).

2.2.2 Wind Resistance

2.2.2.1 Determine roof design wind uplift pressures using Ratings Calculator in RoofNav or Data Sheet 1-28.

2.2.2.2 Install FM Approved roof systems that have a wind rating at least equal to that recommended in RoofNav Ratings Calculator or Table 1. Use components that are FM Approved for use together.

Alternatively, provide prescriptive enhancement options for FM Approved roofing systems in the perimeter and corner areas as follows:

A. For all insulated metal panels (IMP) and lap seam roofs (LSR) in all locations, and for standing seam roofs (SSR) in regions not prone to tropical cyclones, secure the system as required for the field of the roof in accordance with RoofNav. In the perimeter and corner areas, use a purlin and internal clip spacing that is a maximum of one-half and one-third of that required for the field of the roof, respectively.

B. For SSR in regions prone to tropical cyclones, secure systems in accordance with part A above and provide FM Approved external seam clamps (ESC) in accordance with Table 2, Figures 1 and 2. Where ESC are used, they should be of the proper shape and size for the SSR seam they are to be installed on, and should be torqued in accordance with the manufacturers' requirements.

2.2.2.3 Where the interior edge of the perimeter or corner width falls between supports provide increased securement to the next purlin or joist support.

Table 1. Recommended Rating of Field, Perimeter, and Corner Areas for Enclosed Buildings (Zones 1, 2, and 3)

Roof Field Area Design Pressure, (P), (psf) (kPa) ²	Minimum Wind Rating for FM Approved Deck/Above-Deck/Entire ¹ Assembly, psf (kPa)		
	Roof Field Area Enclosed Bldg.	Roof Perimeter Area Enclosed Bldg.	Roof Corner Area Enclosed Bldg.
15 (0.7) < P ≤ 20 (1.0)	60 (2.9)	75 (3.6)	105 (5.0)
20 (1.0) < P ≤ 25 (1.2)	60 (2.9)	90 (4.3)	135 (6.5)
25 (1.2) < P ≤ 30 (1.4)	60 (2.9)	105 (5.0)	165 (7.0)
30 (1.4) < P ≤ 37.5 (1.8)	75 (3.6)	135 (6.5)	195 (9.3)
37.5 (1.8) < P ≤ 45 (2.2)	90 (4.3)	165 (7.9)	240 (11.5)
45 (2.2) < P ≤ 52.5 (2.5)	105 (5.0)	180 (8.6)	270 (12.9)
52.5 (2.5) < P ≤ 60 (2.9)	120 (5.7)	210 (10.0)	315 (14.5)
60 (2.9) < P ≤ 67.5 (3.2)	135 (6.5)	240 (11.5)	345 (16.5)
67.5 (3.2) < P ≤ 75 (3.6)	150 (7.2)	255 (12.2)	395 (18.9)
75 (3.6) < P ≤ 82.5 (3.9)	165 (7.9)	285 (13.6)	420 (20.1)
82.5 (3.9) < P ≤ 90 (4.3)	180 (8.6)	315 (15.1)	465 (22.2)
90 (4.3) < P ≤ 97.5 (4.7)	195 (9.3)	330 (15.8)	495 (23.7)
97.5 (4.7) < P ≤ 105 (5.0)	210 (10.0)	360 (17.2)	540 (25.8)
105 (5.0) < P ≤ 112.5 (5.4)	225 (10.8)	390 (18.7)	570 (27.3)
112.5 (5.4) < P ≤ 120 (5.7)	240 (11.5)	405 (19.4)	615 (29.4)
120 (5.7) < P ≤ 127.5 (6.1)	255 (12.2)	435 (20.5)	645 (30.9)
127.5 (6.1) < P ≤ 135 (6.5)	270 (12.9)	465 (22.2)	690 (33.0)

¹ If a minimum 3 ft (0.9 m) high parapet that is adequately designed for horizontal wind load is provided, treat the corner as a perimeter area.

² For roofs with higher field area design pressures, or to interpolate needed perimeter and corner ratings when the field requirements are between levels, multiply the needed field area design pressure from Table 3, 4, or 5 of DS 1-28 by a safety factor of 2.0 and the respective pressure coefficient for perimeter and corner areas (see Table 6 of DS 1-28), and round up to the next highest 15 psf (0.7 kPa) rating interval.

³ Ratings above apply to enclosed buildings with roof slopes ≤ 7° and roof heights ≤ 60 ft (18 m). For other situations, see the relevant tables in Data Sheet 1-28.

Table 2. Use of ESC for Prescriptive Enhancement of FM Approved SSR in Tropical Cyclone-Prone Regions

Needed Field of Roof Pressure Rating, psf (kPa)	Type of Internal Clip ²	
	Two-piece ¹	One-piece ¹
≤ 90 (4.3)	Not required	Not required
> 90 (4.3) ≤ 135 (6.5)	1 over each internal clip in corners only ¹	1 on each side of the internal clip in corners only
> 135 (6.5)	1 over each internal clip in the perimeter and corners ¹	1 one on each side of the internal clip in the perimeter and corners

¹ See Figure 1.

² In cases where the top part of the internal clip has two separated tabs that engage the seam (see Figure 2), one ESC should be provided over each tab.

2.2.2.4 Where skylights are to be provided, install appropriately rated FM Approved skylights as listed in the *Approval Guide*, Building Materials section (FM Approval Class Number 4431). For SSR, use skylights that are specifically designed for use with such panels (see Figure 3).

2.2.2.5 Where FM Approved LSR or SSR metal panel roofs are to be installed over FM Approved rigid insulation boards, do one of the following:

- A. Secure the SSR clips directly to the top flanges of the purlin, joist, or steel deck (if provided), or
- B. Install the SSR clips over a minimum 4 by 4 in. (100 by 100 mm) by minimum 16 ga (0.06 in; 1.5 mm) steel bearing plate located on top of the insulation and fasten the clips through the insulation and plate into the purlin, joist, or steel deck (if provided).

In either case, provide enhancements as described in Section 2.2.2.2 for perimeter and corner areas.

Where steel deck is provided below the standing seam roof, ensure it is FM Approved and installed per RoofNav and Data Sheet 1-29.



Fig. 1. One piece clip (left) vs. two-piece clip (right)

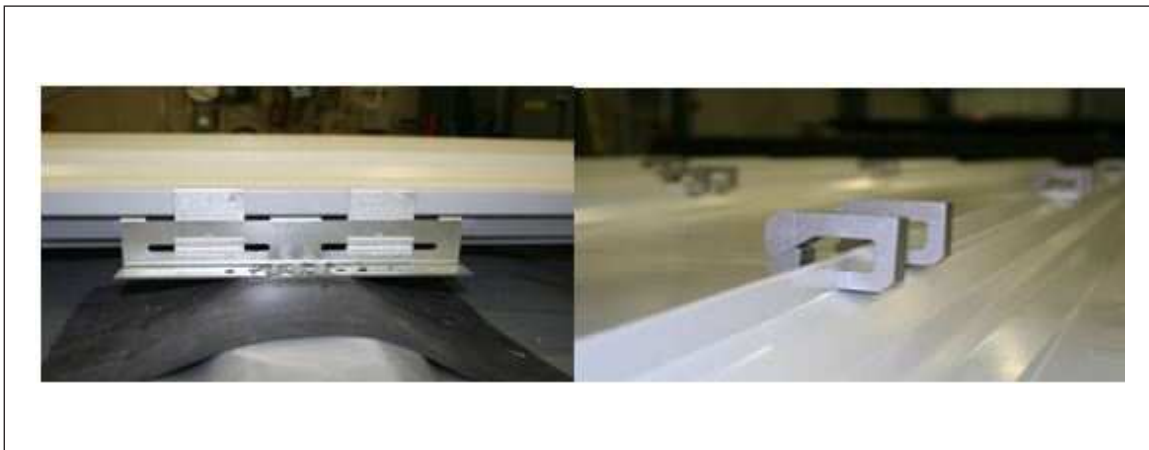

Fig. 2. Note the top part of the internal clip has two separated pieces (left) and requires two ESC (right)

2.2.2.6 Where FM Approved LSR or SSR metal roofs are to be fastened directly to oriented strand cover board (OSB) or OSB/insulation composite boards where the OSB is fastened to the steel deck, install the assembly in accordance with the RoofNav listing and Section 2.2.2.2. Install the OSB in accordance with Section 2.2.2.7.

2.2.2.7 Where metal panel roofs are secured to OSB or OSB composite boards, use OSB that is minimum 7/16 in. (11 mm) thick and rated by the Engineered Wood Association (APA) and classified for either "Exterior" or "Exposure 1" with exterior adhesive. Equivalent products available outside the United States may also be used.

Through-fasten both layers (cover board and insulation) to the steel deck per the RoofNav listing. Use a fastener spacing as required by RoofNav for the needed uplift pressure in each roof zone.

Where prescriptive enhancements are provided based on an assembly approved for the field-of-roof wind ratings, use a minimum of 24 fasteners per 4 by 8 ft (1.2 by 2.4 m) board in the perimeter, and 32 fasteners per 4 by 8 ft (1.2 by 2.4 m) board in the corners.



Fig. 3. Skylight for use in SSR panels

Space the screws and clips for the FM Approved metal roof system to meet the more stringent of the following criteria:

- A. The spacing required by RoofNav for the needed wind rating in each roof area, or
- B. The spacing required based on pull-out tests of the screws from the OSB per Section 3.1.2.

2.2.2.8 Where liner panels are used below the SSR, install the liner panel throughout the entire roof as required by RoofNav for the field-of-roof rating. There is no need to increase fastening of the liner panel in the perimeter or corner areas.

2.2.3 Gravity Loads

2.2.3.1 Ensure panel roof systems are designed for snow and rain loading and drainage in accordance with Data Sheet 1-54, *Roof Loads for New Construction*. Factors that could increase the overall roof load include, but are not limited to, sprinklers, lighting, electrical equipment, ceilings, piping, solar panels, and communication, air-handling, and other mechanical equipment.

2.2.3.2 Ensure panel roof systems have a minimum slope of 1/4 in. per ft (1.2°). Steeper minimum slopes may be recommended by the roof system manufacturer, particularly for lap seam roofs.

2.2.3.3 For new construction of standing seam metal roof systems on cold-formed steel C or Z purlins, ensure the design is in accordance with the American Iron and Steel Institute (AISI) Standard S100-12, *North American Specification for the Design of Cold-formed Steel Structural Members*. For locations outside the United States, comparable local specifications may be followed. The design of the purlins considers their lateral support using one of the following methods:

- A. The purlin capacity used in the design accounts for unbraced length between purlin braces, or
- B. The purlin capacity used in the design is based on testing that simulates the lateral resistance provided by the actual deck and clip assembly, such as AISI S908-13, *Base Test Method for Purlins Supporting a Standing Seam Roof System*.

Note that FM Approved roof systems are NOT tested for snow load resistance.

2.2.4 Re-Cover of Existing Metal Roof Systems

2.2.4.1 Analyze the structure to ensure it can support the additional weight of the new roof without reducing the gravity load capacities below acceptable limits. It is not recommended that the wind or gravity load path from a new roof system go through the existing roof panels. The wind and gravity load path from a new roof system should go directly into the existing secondary structural framing (purlins, joists) that supports the existing roof.

2.2.4.2 Where rigid insulation and roof covers are to be installed over an existing metal roof, use an FM Approved mechanically fastened roof cover fastened directly to the existing secondary structural framing (purlins, joists) that supports the existing roof. Pre-secure the insulation using FM Approved mechanical fasteners.

Do not use adhered or mechanically fastened insulation with an adhered roof cover. Installing the fasteners into the thinner or less-rigid panels at a density greater than that for 22 ga (0.0295 in., 0.749 mm) steel deck based on static pull-out tests alone is not recommended. The more widely spaced ribs of these thin metal panels may allow excessive deck deflection and fastener fatigue (back-out or pull-out) due to the roof cover fluttering in mild winds.

2.2.4.3 If the re-cover roof substantially changes the geometry of the roof, this could affect wind and gravity loads and may require a structural analysis. See DS 1-28 and DS 1-54.

2.2.4.4 Ensure all re-cover construction uses appropriate wind-uplift-rated FM Approved assemblies, where available. Provide perimeter and corner roof areas that need increased uplift pressures with increased securement as described in Sections 2.2.2.2 and 3.1.3.

2.2.4.5 Ensure the new roof cover is specifically FM Approved for re-cover construction on the existing type of metal roof system.

2.2.4.6 Where FM Approved liquid-applied roof covers and polyurethane foam systems FM Approved for spray-applied, direct-to-steel deck are used to re-cover existing metal roof systems, do the following to prepare the surface:

- A. Re-tighten existing exposed fasteners. Analyze the existing deck and install additional fasteners if needed to meet wind load requirements.
- B. If required by the FM Approval of the liquid-applied coating, reinforce the joints with fabric.
- C. Wire brush lightly rusted areas and replace severely deteriorated areas.
- D. Power wash the existing roof prior to the coating application, if required by the FM Approval or by the coating manufacturer.

Follow FM Approval requirements for minimum/maximum slope and application rates. Liquid-applied coatings should meet any minimum wet film thickness (WFT) or dry film thickness (DFT) per the Approval. Test polyurethane foam before applying it to the deck or other substrate to ensure its density is in accordance with FM Approval criteria. Apply a thickness of foam that is within the thickness range for which it is FM Approved.

2.2.4.7 If an existing aluminum-faced metal roof panel is re-covered, consider it Class 2 unless it is specifically FM Approved otherwise.

Use FM Approved stainless steel fasteners to avoid galvanic corrosion.

Provide automatic sprinklers below all Class 2 roof assemblies. Ensure the existing batt insulation is tight to the underside of steel decks, with no significant air space (2 in. [50 mm] or less).

2.2.5 Metal Roof Systems Used to Re-Cover Other Existing Metal Roofs

2.2.5.1 General

2.2.5.1.1 Analyze the structure to ensure it can support the anticipated loads without reducing the gravity load capacities below acceptable limits. The increase in load due to the new roof system and framing may be offset by removing any existing gravel surfacing or above-deck components.

2.2.5.1.2 Remove all wet insulation in the existing roof system. For additional information, see Data Sheet 1-29.

2.2.5.2 Assemblies with No Concealed Spaces

For an example, see Figure 4.

2.2.5.2.1 For installations over existing roof systems, use an FM Approved assembly for the specific type of roof being covered.

2.2.5.2.2 Anchor framework installed over openings (e.g., windows in saw-tooth roofs) to existing structural members and reinforce as needed to resist the design wind loads. Ensure the purlin thickness, yield strength, and maximum spacing between purlins meets the RoofNav criteria for the new metal roof.

2.2.5.2.3 Use one of the following over any existing roof system or over openings (e.g., windows in saw-tooth roofs):

- A. Unfaced noncombustible-core, FM Approved insulation.
- B. Unfaced glass fiber or mineral wool batt insulation or FM Approved facings and glass fiber batt insulation with the facer down.
- C. Other insulations that pass ASTM E136 or ASTM E2652 (using pass/fail criteria per ASTM E136).

Alternatively, install insulation that has passed FM 4880 without a thermal barrier over glass walls in saw-tooth roof systems.

2.2.5.2.4 Where the existing roof is an insulated steel deck, has an expansion joint, and the above-deck components include extruded or expanded polystyrene or a multi-ply roof cover, do **both** of the following:

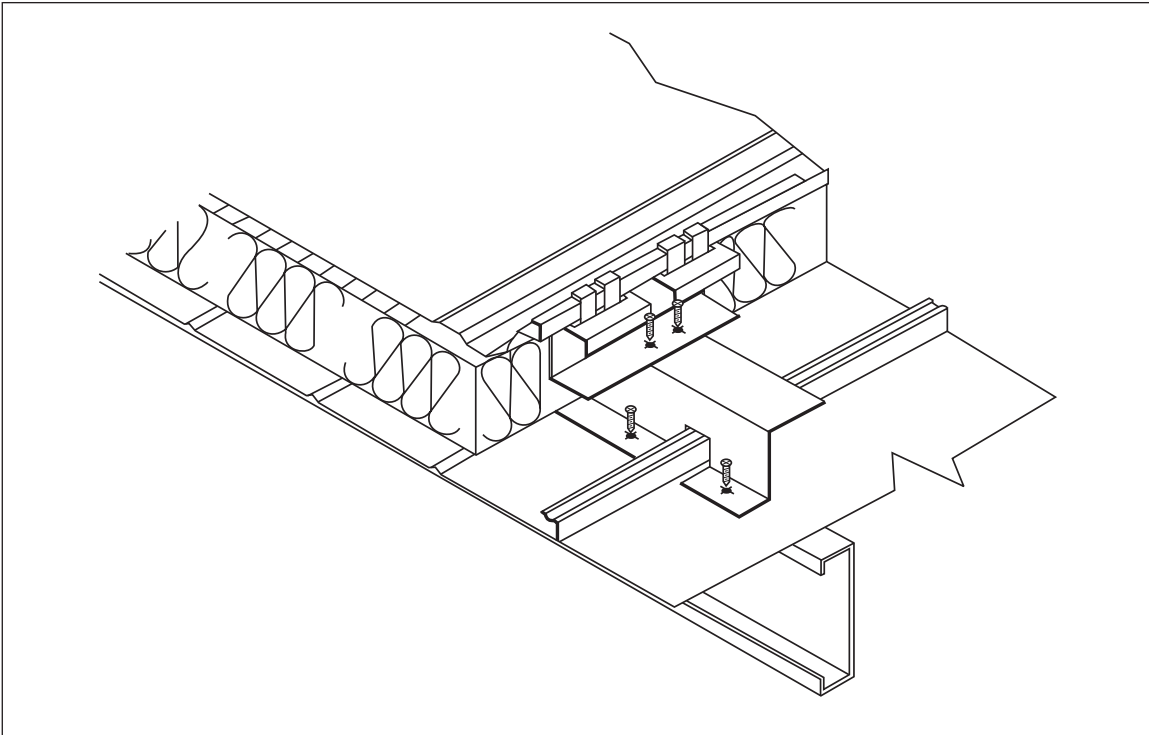

Fig. 4. Re-roof assembly with noncombustible or Class 1 insulation added above the existing roof and no concealed spaces

A. Fill any existing expansion joints with a noncombustible compressible insulation such as mineral wool (filling the existing expansion joints with mineral fiber is intended to reduce fire spread through the roof deck in either direction), and

B. Cover any existing expansion joints with steel coping.

2.2.5.3 Assemblies With Concealed Spaces

2.2.5.3.1 Evaluate items in Sections 2.2.5.3.2 through 2.2.5.3.6 prior to installing a metal roof system over an existing roof assembly that will be left in place (see Figure 5).

2.2.5.3.2 Ensure framing for the metal roof system is noncombustible and adequately secured to the existing structural supports.

2.2.5.3.3 If combustible above-deck components are to remain, fill the expansion joints in the existing roof with noncombustible compressible insulation (e.g., ceramic or mineral fiber) and cover with minimum 22 ga (0.0295 in.; 0.749 mm) sheet steel fastened in place. Ensure thermal movement is not restricted.

2.2.5.3.4 If insulation is to be added, use one of the following over an existing roof system or over openings (e.g., windows in saw-tooth roofs):

A. Unfaced noncombustible-core FM Approved insulation.

B. Unfaced glass fiber or mineral wool batt insulation or FM Approved facings and glass fiber batt insulation with the facer down.

C. Other insulations that pass ASTM E136 or ASTM E2652 (using pass/fail criteria per ASTM E136).

2.2.5.3.5 If the existing roof is Class 1 and insulation is to be added, limit it to 1 in. (25 mm) maximum thickness unless specifically tested or FM Approved otherwise.

2.2.5.3.6 When a metal roof system is installed over an existing roof assembly, a combustible concealed space can be formed (Figure 5). If the existing roof assembly has an American Society for Testing and Materials (ASTM) E108 Class A-rating or is gravel surfaced and the gravel will remain, no other protection is needed. If this is not the case, do **one** of the following:

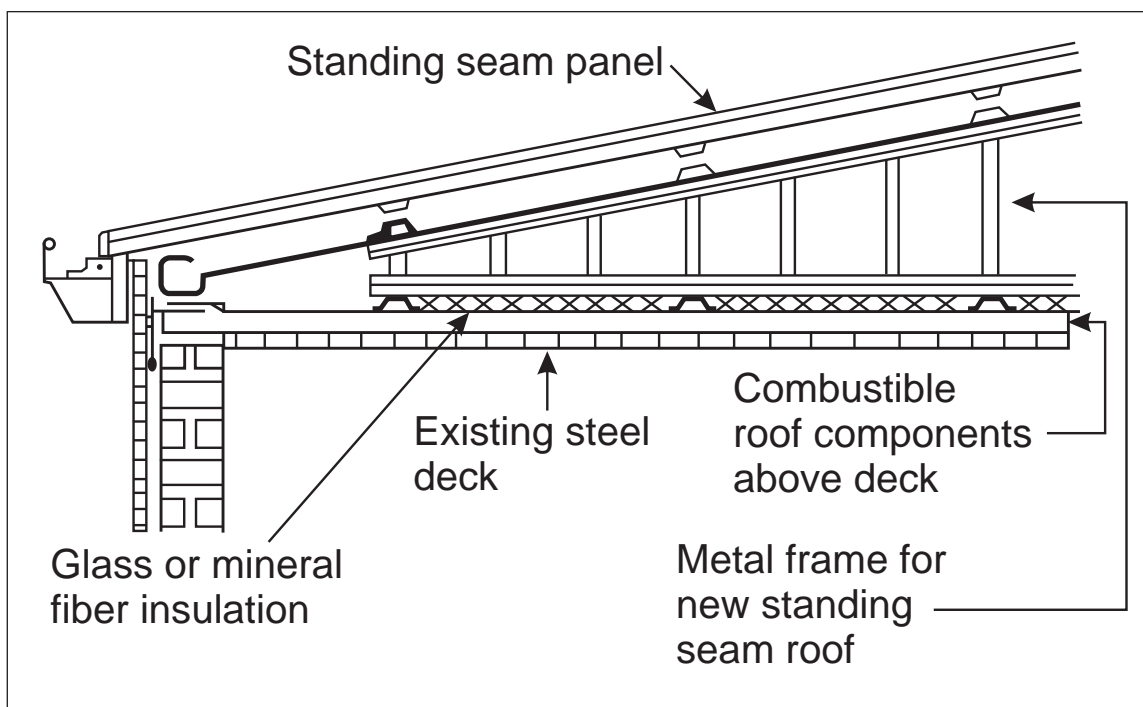

Fig. 5. Standing seam roof in re-cover construction resulting in a concealed space

- A. Remove all above-deck components, including adhesive, down to the bare steel deck. Note: If the existing deck is wood, or significant adhesive remains, cover with minimum 1/2 in. (13 mm) thick gypsum board (ordinary gypsum board is acceptable) prior to the installation of the framing system.
- B. If the existing roof assembly is smooth surfaced, multi-ply cover, and the deck is Class 2 insulated steel, wood deck, or concrete, protect the roof cover with a minimum of 6 in. (152 mm) of unfaced glass or mineral fiber batts.
- C. Provide dry-pipe automatic sprinklers in the space in accordance with DS 2-0 and DS 3-26. Consider this option only if there will be sufficient access to the sprinkler system (e.g., hatchways in the existing roof). Also, the new and existing framing must be capable of supporting the additional weight. Ensure the new assembly does not obstruct sprinkler water flow to roof drains.

Noncombustible framing is recommended for new installations. Dry-pipe sprinkler protection is acceptable to protect existing combustible framing, and/or combustible insulation or roofing material.

Combustible materials within concealed spaces can be protected with an FM Approved fire-protective coating. Most Approved coatings can be found in the Building Materials section of the *Approval Guide* by clicking on the "Fire Retardant Coatings" section. Then click on "Fire Retardant Coatings for Interior Finish Materials (Class 4975)." FM Approved coatings include cementitious, mineral fiber-based, intumescent fire-retardant paints, and fire-retardant cellulosic fiber. They must only be applied over the specific types of materials that they are FM Approved for use over, and the required minimum coating thickness may vary for different substrates. "Fire Protective Coatings" Approved under the heading "Wall/Ceiling Construction (Class 4880)" are also acceptable with the same limitations as noted for Class 4975.

2.3 Operation and Maintenance

2.3.1 Provide regular maintenance of gutters and parapets to keep them clear of snow, ice, and debris in the spring and fall and after significant storms. Use open-channel (three-sided) conductors (leaders, downspouts) in areas where multiple snow storms can be expected in any given winter season. Another option is to truncate down-spouts above potential snow banks or points of possible vehicle impact (parking areas, truck docks, etc.). Remove snow and ice accumulations around closed conductors. Use heat tracing and/or open-channel conductors for gutters and conductors with a history of ice blockage.

2.3.2 Replace missing nuts and bolts. Ensure buckled, missing, or loose braces are replaced, tightened, or secured as necessary. This includes purlin-to-beam connections, purlin-to-purlin lap connections and braces, and purlin-to-beam brace connections. Replace any purlins that are deformed (twisted sideways or buckled). This applies to all panel roof systems.

3.0 SUPPORT FOR RECOMMENDATIONS

3.1 Additional Information

3.1.1 Structural Design

The wind-load design of panel roof systems built to other specifications may not be as stringent as those conforming to FM Approval requirements and the recommendations in this data sheet.

Roof deck and purlins or joists are typically designed for uniformly distributed loads. Constructing a framing system above the existing deck to support a re-cover system may load the structure with point (concentrated) loads. This loading is usually a more critical case. The analysis must take into account any concentrated live, snow, wind, and dead loads from the new standing seam system, plus the distributed dead loads from the existing roof.

When designing a new panel roof system, it may be prudent to include an allowance for future dead loads due to possible re-cover, PV panels, or other roof-mounted equipment. Otherwise, future re-cover and equipment options may be limited to coating systems or roof panel replacement. If these future limitations are deemed sufficient, an additional allowance may not be cost-effective.

3.1.2 Oriented Strand Board (OSB)/Composite Systems

There are several FM Approved combinations of a standing seam roof secured to an OSB coverboard or OSB/composite coverboard or insulation. These should be used within the limitation of their FM Approval (see Figure 6).

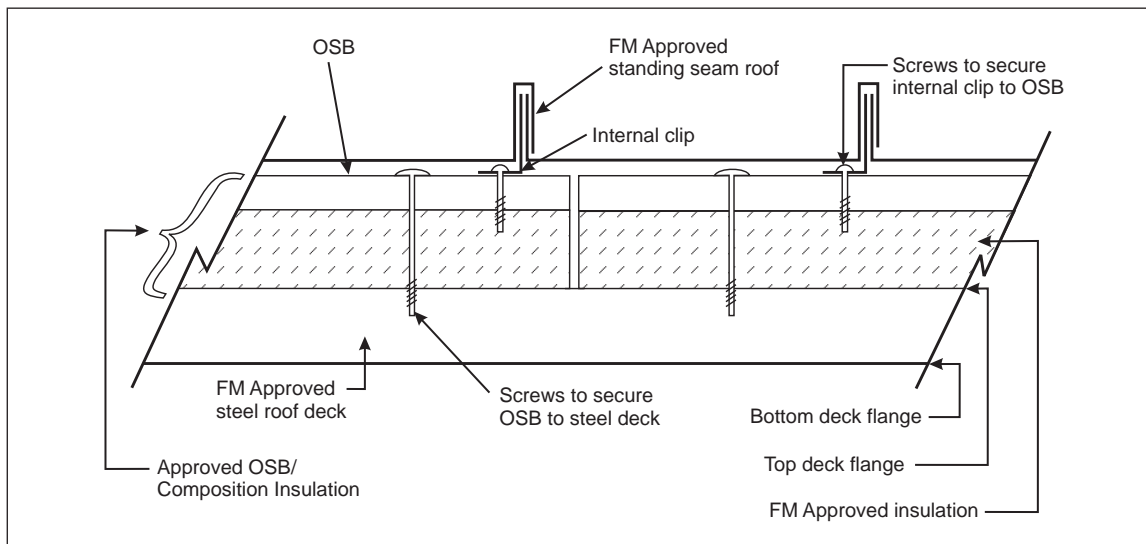

Fig. 6. FM Approved Standing seam roof applied to OSB/composite insulation. Redraw to make steel deck deeper and label top flange of deck

Fastener pull-out resistance from **existing** OSB boards should be obtained by field tests. Testing should be done in accordance with ANSI/SPRI FX-1, Standard Field Test Procedure for Determining the Withdrawal Resistance of Roofing Fasteners. No less than five tests should be conducted, regardless of roof size.

3.1.3 Re-Cover of Metal Roof Systems

Use only insulations specifically FM Approved for re-cover of metal roof systems as noted in the recommendations in this standard or that have been proven to meet these requirements as proven by FM Approvals Construction Materials Calorimeter testing.

Single-ply roof cover fasteners FM Approved for steel deck re-cover systems are designed for use in minimum 22 ga (0.0295 in.; 0.749 mm) steel deck. Adequate pull-out resistance would not be obtained if they were driven into thinner 24-26 ga (0.0237-0.018 in.; 0.607-0.457 mm) metal roof systems. Adequate securement can be obtained by driving the roof cover fasteners into the secondary structural framing (e.g., purlins or joists). Installing the fasteners into the thinner panels at a density greater than that for 22 ga (0.0295 in.; 0.749 mm) steel deck based on static pull-out tests alone is not recommended. The more widely spaced ribs of these thin metal panels may allow excessive deck deflection and fastener fatigue (back-out or pull-out) due to the roof cover fluttering in moderate winds.

The number of fasteners used for securing insulation to these thinner decks with mechanically-secured, single-ply roof covers should be 50% greater than that recommended for 22 ga (0.0295 in.; 0.749 mm) steel deck. The reason is that the fastener pull-out resistance is less in the thinner metal panels than that obtained with 22 ga (0.0295 in.; 0.749 mm) steel deck. Fastener fatigue is not considered a major concern for preliminary securement of insulation because the insulation is not subject to the same cyclic loading as the mechanically secured roof cover.

Some liquid-applied roof covers have minimum and maximum slopes for which they are FM Approved. The minimum slope requirement is needed as some products are not tolerant of ponded water. The maximum slope requirement is needed to limit exterior flame spread.

Spray-applied polyurethane foam that is applied directly to existing metal roof systems, but does not meet FM Approval criteria regarding product type or installation requirements, could constitute a Class 2 (combustible) roof assembly.

3.1.4 Roof Areas Needing Increased Fastening

Increased securement of roof systems is needed at the roof corners and perimeter due to the higher uplift pressure in these areas. Higher uplift pressure also occurs at the roof peak on roofs sloped greater than 7° (1.5 in. per 12 in. [38 mm/305 mm]). Use the methods outlined below to increase fastening density in the specific areas recommended in Data Sheet 1-28.

Increased securement is achieved by decreasing the distance between fastener rows. However, it is not a practical method for some metal roof systems, so other means are used.

Use **one** of the following methods for increasing the securement of the roof system in the roof perimeter and corners:

- A. Use an FM Approved roof system with the appropriate wind uplift rating in each area per Table 1, or
- B. Use an FM Approved assembly for the field of roof, and use the appropriate type of prescriptive enhancement listed below. If there is an existing panel roof, ensure it is adequately secured for the expected uplift pressures in each roof area.

3.1.4.1 Single-Ply Re-Cover System Secured Through Existing Metal Panel Roofs Directly to Purlins

It is not practical to provide additional rows of fasteners for re-cover systems in which the mechanically-attached, single-ply roof cover is secured directly to the purlins (see Figure 7) because the existing purlins are at a fixed distance, typically 4 to 6 ft (1.2 to 1.8 m) on center. For these cases, it would be acceptable to increase the fastening density of the new single-ply roof cover by decreasing the spacing between fasteners along each fastener row or batten bar in the noted areas. The fastener spacing should be a maximum of 60% and 40% of the FM Approved spacing (i.e., field of roof spacing) in the perimeter and corners respectively, but no closer than 3 in. (76 mm). If there are additional purlins in the areas needing increased securement, the needed increase in fastening of the roof cover can be achieved by providing additional rows of fasteners (i.e., per Data Sheet 1-29). Pre-secure the insulation per DS 1-29.

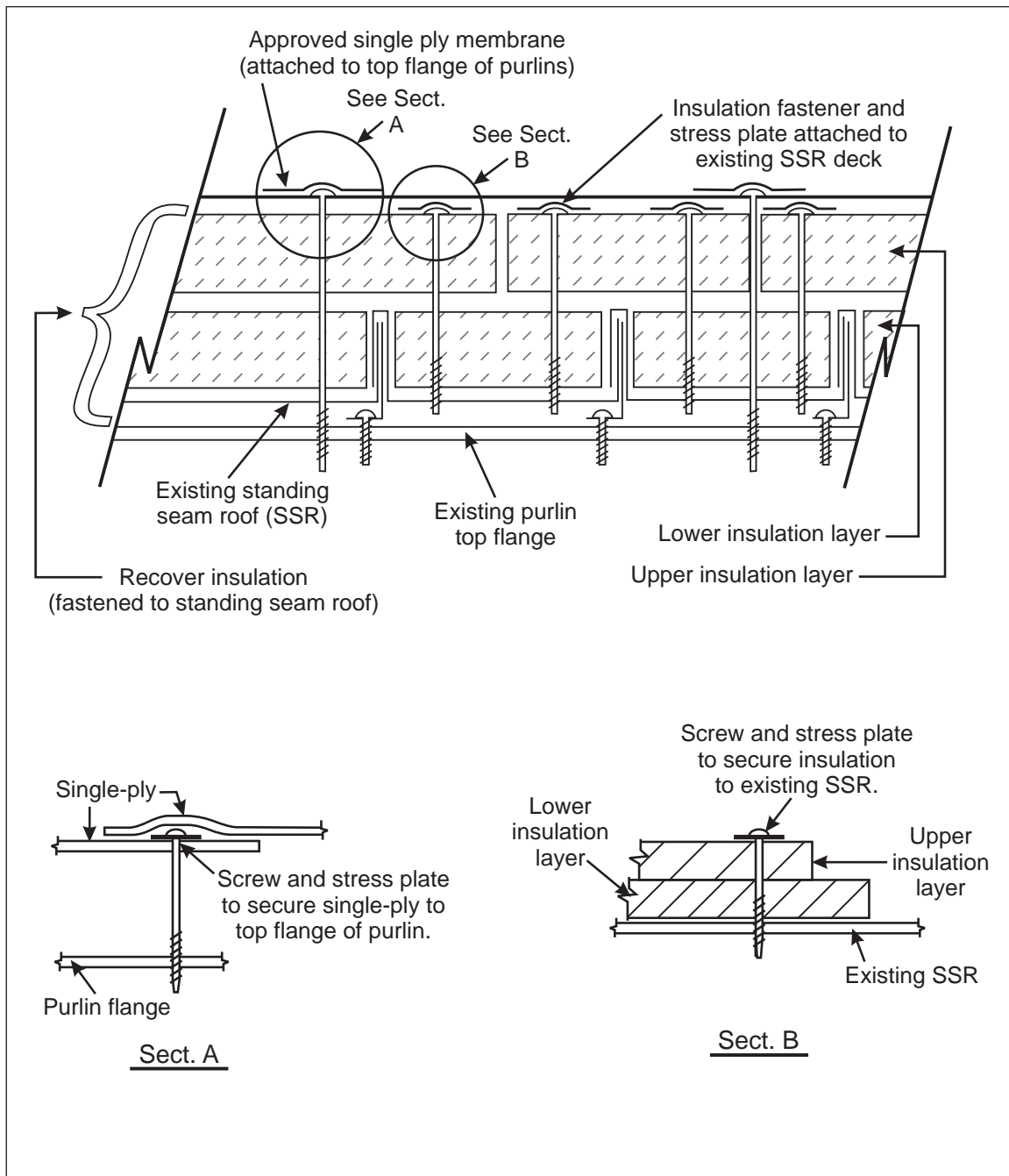

Fig. 7. Typical re-cover of existing standing seam roof using a mechanically fastened single-ply roof cover

3.1.4.2 Standing Seam Roof Secured to Purlins

For new construction of standing seam roofs secured directly to purlins, install the clips at each purlin/seam intersection (Figure 2). Reduce the spacing between purlins to provide the needed increased wind resistance in the perimeter or corners of the roof. Using narrower panels on the perimeter or corners (vs. the field-of-roof) is not practical. Space these purlins a maximum of 1/2 and 1/3 times the spacing in the field of the roof in the perimeter and corners, respectively.

Example: Field of roof purlin spacing of 5 ft (1.5 m) would have perimeter spacing of 2.5 ft (0.76 m) and corner spacing of 1.67 ft (0.5 m).

3.1.4.3 New Construction: Standing Seam and Lap Seam Roof Secured to OSB/Composite

For metal roof systems secured to OSB/composite board, ensure the spacing between clips along the panel joints is a maximum of 1/2 and 1/3 times the spacing in the field of the roof in the perimeter and corners respectively.

3.1.4.4 Lap Seam Roof Systems

For new construction, ensure the maximum panel span and securement is in accordance with RoofNav requirements.

3.1.5 Wind Resistance of Standing Seam Roofs

There are several failure modes that can occur with SSRs during wind uplift. They include:

- A. The SSR bowing between the panel ribs and releasing from the internal clips.
- B. Pullout of the screws securing the internal clips to the purlins or joists.
- C. Breakage of the internal clips.

Failure modes B and C would generally be based on an equivalent vertical force per clip, and the pressure resistance would tend to increase linearly with a decrease in the area per clip. Screw pullout resistance will increase as the purlin thickness and yield strength increases, as well as the diameter and number of screws increases.

While deflection of the SSR deck occurs between purlins, the deflection between the deck ribs can be even more significant. Failure mode A is a function of the uplift pressure applied to the panel and the resulting bowing of the panel between ribs. As the pressure increases, so does the bowing of the panels between panel ribs. Eventually, the panel seams can release from the internal clips. As such, the wind uplift resistance may not increase linearly with a decrease in the area per internal clip. Comparative test data shows that, in some cases, cutting the spacing in half results in only a one-quarter to one-third increase in wind resistance.

To optimize the wind resistance of the SSR panel, it should stay attached to the internal clip until about the same pressure as that which causes the clip to break or the clip screws to pull out of the purlins.

The use of external seam clamps (ESC) or wind clamps over the internal clips tends to increase the uplift resistance of the SSR by keeping the deck seams attached to the internal clips at higher wind uplift pressures. **It is vitally important that the external clamps fit properly on the deck seams.** With ESC, wind resistance is more likely to increase linearly with a reduction in the spacing of the purlins and internal clips. Tests have shown that, in some cases, properly fitting external seam clamps can double or triple the wind pressure resistance of the same SSR system without the clamps, all else being equal.

3.1.6 Providing Enhancements for Existing SSRs and Leakage Concerns

Using External Seam Clamps (ESCs) is preferred over through-fastening as a method to enhance wind uplift resistance of standing seam roofs (SSR). If through-fastening is used, added precaution must be taken to prevent roof leakage.

3.1.7 Sub-Purlins Used for the Securement of FM Approved Panel Roofs Over Existing Roofs

Sub-purlins usually consisting of 16 or 14 gauge (0.060 or 0.075 in.; 1.5 or 1.9 mm), minimum 50,000 psi (345 MPa) yield strength steel are used to secure a new metal roof over an existing one. The sub-purlins should run over and be screwed into the existing purlin. If the original construction has adequate purlin bracing, a system such as this could be used if an SSR (FM Approved for the necessary wind rating) was fastened to the sub-purlins. There are FM Approved systems available that use such sub-purlins.

3.2 Roof Walkways

Many panel roofs do not have a significant amount of roof top equipment that requires frequent access for maintenance. In situations where that is not the case and roof areas are subject to frequent foot traffic, consider providing roof-top walkways to avoid damage to the roof system.

4.0 REFERENCES

4.1 FM Global

Data Sheet 1-22, *Maximum Foreseeable Loss*

Data Sheet 1-28, *Wind Design*

Data Sheet 1-29, *Roof Deck Securement and Above-Deck Roof Components*

Data Sheet 1-54, *Roof Loads for New Construction*

Data Sheet 1-55, *Weak Construction*

Data Sheet 1-57, *Plastics in Construction*

The *Approval Guide*, an online resource of FM Approvals

RoofNav, an online resource of FM Approvals for roofing professionals

Understanding the Hazard: *Collapse of Metal Roof Systems*, P0043

Understanding the Benefit: *FM Approved Lap Seam Roofs*, P10225

4.2 Others

American Iron and Steel Institute (AISI). *North American Specification for the Design of Cold-Formed Steel Structural Members*. Latest edition.

American Iron and Steel Institute (AISI). *Base Test Method for Purlins Supporting a Standing Seam Roof System*. AISI S908-13.

APPENDIX A GLOSSARY OF TERMS

See Data Sheet 1-28 for additional terms related to wind design.

Collateral load: Hung weight, dead loads separate from and supported by the roof framing, such as piping, ductwork, equipment, etc.

Composite panels: Wall or roof panels made of glass fiber reinforced plastic.

External Seam Clamp (ESC): A mechanical device, typically made of extruded aluminum, that fits over the seam of a standing seam roof (SSR), at or near the internal clip. The device may be used to enhance wind resistance of the SSR or secure roof mounted equipment.

Fixed clip: A one-piece internal clip seamed into mating panels of a standing seam roof that is used to connect the roof panels to their supporting structural members (purlins, joists). Thermal expansion is accommodated by allowing movement between the internal clip and the seam.

FM Approved: Products or services that have satisfied the criteria for FM Approval. Refer to the *Approval Guide*, an online resource of FM Approvals, for a complete listing of products and services that are FM Approved.

Hurricane-prone regions: See “tropical cyclone-prone regions.”

Insulated metal panel: A panel having an internal and external metal face and insulation in between.

Lap seam roof: A metal or plastic panel that is through fastened to the structural members that support it.

Panel roof system (MRS): As used in this document, the term refers to a; standing seam metal roof system, lap seam metal or plastic roof system, insulated metal panel roof system or composite panel roof system.

Sliding clip: A two-piece clip seamed into mating panels of a standing seam roof that is used to connect the roof panels to their supporting structural member. The top portion of the clip is thin (usually 24 or 26 ga, 0.024 in. to 0.019 in., 0.60 to 0.48 mm) to allow it to fit between the two interlocking edges of mating panels. The base of the clip is relatively thick and is fastened to the top flange of the purlin. A slot in the base of the clip allows for thermal expansion (often about 9/16 to 1 in., 14 to 25 mm, in either direction) from its center.

Standing seam roof: A metal roof that is secured by using fixed or sliding internal clips located within their seams that are secured to the top flange of steel purlins using screws.

Tropical cyclone-prone region: An area prone to tropical storms in which winds rotate about a center of low atmospheric pressure, clockwise in the southern hemisphere and counter-clockwise in the northern hemisphere. This includes locations prone to hurricanes, typhoons and cyclones and includes the following regions:

1. The U.S. Atlantic Coast and Gulf of Mexico Coast, including parts of Mexico and Central America, where the basic wind speed per DS 1-28 is greater than 90 mph, and
2. Hawaii, Puerto Rico, Guam, Virgin Island, and American Samoa.

For locations outside the United States, any areas that are in a “tropical cyclone” region or “typhoon-prone” region. This includes, but is not limited to, parts of Australia (green, blue, and red banded areas) and the northern part of the north island of New Zealand, Bermuda, the Bahamas, India, Bangladesh, the Philippines, Japan, South Korea, Hong Kong, Macau, Vietnam, Burma (Miramar), China, Sri Lanka, Hong Kong, Macau, Cambodia, Madagascar, Taiwan and the southeast coast of Brazil, where the basic wind speed per DS 1-28 is greater than 90 mph.

Typhoon-prone region: See “tropical cyclone-prone locations.”

APPENDIX B DOCUMENT REVISION HISTORY

July 2016. This data sheet has been completely revised. Major changes include the following:

- A. Changed the title of the document from *Metal Roof Systems* to *Panel Roof Systems* to reflect that wind guidance is also to be applied to through-fastened plastic and composite panel roof systems.
- B. Added information regarding the use of external seam clamps (ESC) to increase the wind resistance of standing seam roofs (SSR). This information applies to the enhancement of new installations and retrofitting of existing installations.

January 2010. The following changes were made:

- The document was simplified
- Recommendations were reformatted
- Discussion was added regarding the use of external seam clamps on standing seam roofs
- Changes were made to prescriptive enhancements for wind uplift resistance of standing seam roofs in regions prone to tropical storms
- Slight changes were made to Table 1 for consistency with Data Sheet 1-29

July 2008. Table 1 was made consistent with revisions in Data Sheet 1-28, *Wind Design*, and Data Sheet 1-29, *Roof Deck Securement and Above-Deck Roofing Components*. This change raised the safety factor in the perimeter and corner areas to 2.0. Prescriptive perimeter and corner enhancements remain unchanged. Recommendation 2.2.4 relating to gravity loads was added.

May 2003. Clarifications were made to recommendations in the Section 2.2.3, “Metal Roof Systems Used for Re-cover.”

May 2002. Clarification was made to recommendation 2.2.2.1 under Section 2.2.2, Re-cover of Metal Roof Systems.

January 2000. That revision of the document was reorganized to provide a consistent format and to consolidate related Engineering Bulletins.

January 1999. Table 1 was completely revised.

June 1996. Editorial changes were made.

June 1992. First edition of “Metal Roof Systems”.

APPENDIX C SUPPLEMENTARY INFORMATION

C.1 Metal Panel Types

There are three basic types of metal roof systems: lap seam, standing seam, and insulated roof deck panel systems.

C.1.1 Standing Seam and Lap Seam Roofs

These metal roof systems are typically formed using 20-26 ga (0.036-0.018 in., 0.914-0.457 mm) steel. Copper and aluminum may also be used for standing seam panels. Steel panels are usually coated with zinc or zinc-aluminum alloys and/or painted to minimize corrosion. Standing seam panels are usually 12-24 in. (305-610 mm) wide. Lap seam panels are generally wider, about 48 in (1.2 m). The limiting factor for panel length is usually transportation restrictions.

For new construction, the panels are usually secured to supporting members called purlins. The purlins are C or Z shaped cold-rolled members. They are usually 12-16 ga (0.105-0.059 in., 2.667-1.500 mm) steel. In some cases, bar joists are used.

Lap seam roofs are cold-formed steel panels that are fastened through the panels and directly to the purlins or joists with self-drilling fasteners. The fasteners include a washer under the head to seal against leakage. A sealant is typically applied within the laps to provide waterproofing. FM Approved systems are listed in RoofNav. Lap seam roofs may be corrugated or can be formed with large flat areas between the ribs, resembling standing seam panels.

A potential problem with this type of roof is that movement caused by thermal expansion can induce stress on the fasteners and panel joints. Screw holes can become elongated and the sealants in the panel joints can crack. Both situations can cause leaks.

Standing seam roofs also consist of cold-formed metal panels, but they are not through-fastened to the purlins. Instead, clips (Figure 1) are fastened to the purlins. The panel is then secured to the clips within the panel joints (Figure 2). The edges of the panels form a tight seal, usually 2 to 4 in. (51 to 102 mm) above the flat portion of the roof. Some systems include a sealant in the joint. Under usual conditions, this keeps the seam above the level of water on the roof and maintains water tightness. However, if gutters or downspouts become blocked, leakage can occur. The concealed clips do not penetrate the panel and allow for movement caused by thermal expansion. Two-piece clips allow thermal movement to take place between the upper and lower portions of the clip. One piece clips allow thermal movement to occur between the seam and top of the clip.

The standing seam panels can be joined using a proprietary machine or hand tools. These seams are formed in one of two ways: panel edges can be folded over each other, or a separate strip (batten) can be put over the two edges and crimped together. A third type of joint does not incorporate crimping. The panels simply snap together when installed. The end laps of all types are usually simple overlaps and are screwed together immediately on the down-slope side of the purlin or joist, with a sealant applied between the layers.

Adequately sized and fastened clips can provide the necessary wind uplift resistance while allowing the panels to move in the longitudinal direction. To accommodate this movement, only one end of the panels is restrained. Typically, the panels are secured with through-fasteners at the eave strut and clip fasteners upslope of the eave. This allows the roof to expand at the ridge. Ridge caps are designed to accommodate this movement.

Both roof types are usually insulated on the underside with glass fiber batts and a vapor retarder, or other approved insulation. A metal liner panel may also be installed on the underside. The liner is usually of thinner gage than the roof panel. In most systems, the liner is not part of the wind load path and does not add uplift strength to the assembly.

C.1.2 Insulated Roof Deck Panels

A variation of the above systems is the insulated metal sandwich panel that consists of metal skins with a thermoset foam plastic or mineral wool core. These are typically factory assembled. They can be attached with clips, similar to standing seam roofs or through fastened. FM Approved panels are listed in RoofNav.

Some panel roof assemblies have a metal facing on the bottom, thermoset foam plastic insulation and a thermoplastic roof cover above. The panels are factory assembled. The metal bottom panel is fastened to the purlins or joists on site and adjacent sections of the thermoplastic roof cover are heat welded to provide waterproofing at the panel joints.

C.2 OSB/Composite Systems

A common installation for standing seam roof systems consists of an OSB/composite insulation mechanically secured to standard FM Approved deep steel roof deck. The standing seam clips are then fastened to the OSB top surface of the insulation. Typical OSB/composites have a 7/16 in. (11 mm) thick OSB top surface that offers considerably less fastener pull-out resistance than steel purlins.

C.3 Re-Cover of Metal Roof Systems

Metal roof systems are commonly re-covered with coatings or single-ply roof cover systems. Many existing metal roofs are only 24 to 26 ga (0.607 to 0.457 mm); hence, adequate mechanical securement to the roof panel itself is difficult. Single-ply systems specifically FM Approved for re-cover over existing metal roof systems should be installed and fastened as FM Approved in the field of the roof and enhanced as outlined at the corners/perimeter/peak.

C.4 Metal Roof Systems Used for Re-Cover

Metal roof systems may be used to re-cover existing low-sloped BUR systems. For these installations, a framing system is constructed over the existing BUR (Figure 2). It may be necessary to remove the gravel surfacing to reduce the dead load to the structure. In that case, precautions are needed to prevent a potential concealed space fire. New framing supports are secured through the existing roof covering to the deck or existing purlins. The new metal roof system is then secured to the new framing. This installation allows for improved drainage as the new standing seam system can (and should) be sloped.